

# DCM100

## Direct Current Monitor

The DCM100 DC Monitor is an advanced electronic monitoring device used to measure the voltage and current of any direct current (DC) power source or load. Examples of DC power sources that can be monitored with the DCM100 include batteries, alternators, solar panels, and wind generators. The DCM100 can also be used to monitor DC loads like inverters, windlasses, DC refrigerators, or any DC branch circuit. When the DCM100 is used to monitor batteries, sophisticated circuitry and software algorithms monitor battery temperature, load current, charging current and terminal voltage to precisely compute battery state of charge, and time remaining. To measure current, the DCM100 uses an included state-of-the-art Hall effect current sensor which simply slips over the wire—you don't have to break connections or install connectors as you do with inline shunts used in other solutions. Best of all, the DCM100 is NMEA 2000® certified so you can view any and all DC information anywhere on the vessel using a compatible NMEA 2000 display. The DCM100 is a key component of Maretron's N2KView® vessel monitoring and control system.



### Information monitored:

- Battery Voltage
- Battery Current
- Ripple Voltage
- Battery Case Temperature
- State of Charge
- Time Remaining
- Charge Efficiency Factor

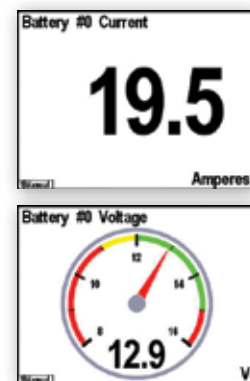

DSM Series Screen Shots



TSM Series Screen Shot

Available accessory is for the DCM100:



FC01



LEMHTAx00-S



TR3K

### PRODUCTS

PART NUMBER	DESCRIPTION
DCM100-01	Direct Current (DC) Monitor w/ 200 Amp Current Transducer (includes FC01, LEMHTA200-S and TR3K)
FC01	DCM100 Battery Harness with Fuse
LEMHTA200-S	200 Amp Current Transducer with Cable
LEMHTA400-S	400 Amp Current Transducer with Cable
LEMHTA600-S	600 Amp Current Transducer with Cable
TR3K	DCM100 Ring/Under Bolt Temperature Probe

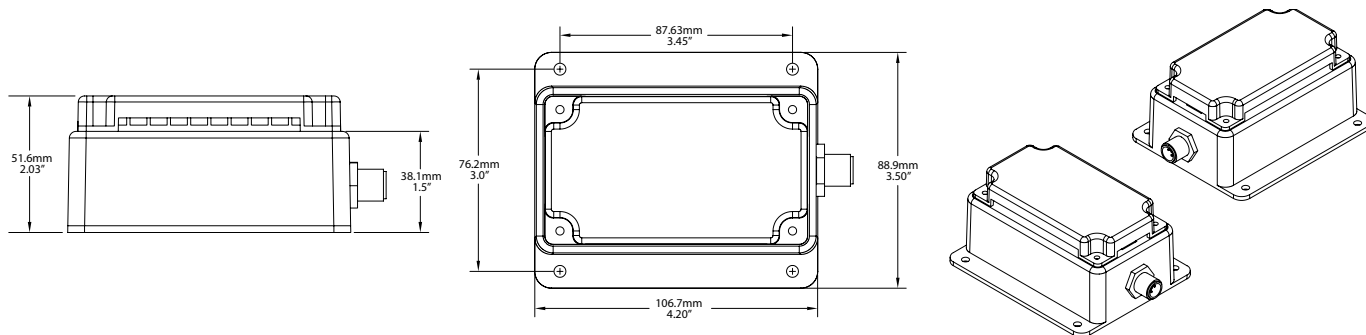

## SPECIFICATIONS

PARAMETER	VALUE	COMMENT
Battery Sense Voltage Range	0 to 50 VDC	
Battery Sense Voltage Accuracy	±100 mV	
Battery Current Range	0 to 200A	With included Hall-effect current sensor
Battery Current Accuracy	±1 %	With included Hall-effect current sensor

## NMEA 2000® PARAMETER GROUP NUMBERS (PGNs)

DESCRIPTION	PGN#	PGN NAME	DEFAULT RATE
Periodic Data PGNs	127506	DC Detailed Status	0.67 times/second
	127508	Battery Status	0.67 times/second
	127513	Battery Configuration Status	N/A
Response to Requested PGNs	126464	PGN List (Transmit and Receive)	N/A
	126996	Product Information	N/A
	126998	Configuration Information	N/A
Protocol PGNs	059392	ISO Acknowledge	N/A
	059904	ISO Request	N/A
	060928	ISO Address Claim	N/A
	065240	ISO Address Command	N/A
	126208	NMEA Request/Command/Acknowledge	N/A
Maretron Proprietary PGNs	126720	Device Configuration Information	N/A
	130818	Device Label	N/A

## ELECTRICAL

PARAMETER	VALUE	COMMENT
Operating Voltage	9 to 32 Volts	NMEA Interface
	9 to 32 Volts	Battery Interface
Power Consumption (Battery Interface)	70mA	
Power Consumption (NMEA 2000® Connection)	50mA	
Load Equivalence Number (LEN)	1	NMEA 2000® Spec. (1LEN = 50mA)
Reverse Battery Protection	Yes	Indefinitely
Load Dump Protection	Yes	Energy Rated per SAE J1113

## MECHANICAL

PARAMETER	VALUE	COMMENT
Size	3.50" x 4.20" x 2.03" (88.9mm x 106.7mm x 51.6mm)	Including Flanges for Mounting
Weight	13 oz. (368.5 g)	

## ENVIRONMENTAL

PARAMETER	VALUE
IEC 60945 Classification	Exposed
Degree of Protection	IP64
Operating Temperature	-25°C to 55°C
Storage Temperature	-40°C to 70°C
Relative Humidity	93%RH @40° per IEC60945-8.2
Vibration	2-13.2Hz @ ±1mm, 13.2-100Hz @ 7m/s² per IEC 60945-8.7
Solar Radiation	Ultraviolet B, A, Visible, and Infrared per IEC 60945-8.10
Corrosion (Salt Mist)	4 times 7days @ 40°C, 95%RH after 2 hour Salt Spray Per IEC 60945-8.12
Electromagnetic Emission	Conducted, Radiated Emission per IEC 60945-9
Electromagnetic Immunity	Conducted, Radiated, Supply, and ESD per IEC 60945-10
Safety Precautions	Dangerous Voltage, Electromagnetic Radio Frequency per IEC 60945-12

## CERTIFICATIONS

PARAMETER	COMMENT
NMEA 2000® Standard	Level A
Maritime Navigation and Radio Communication Equipment & Systems	IEC 61162-3
Maritime Navigation and Radio Communication Equipment & Systems	Tested to IEC 60945
FCC and CE Mark	Electromagnetic Compatibility